



Lázaro Ituarte Internacional, S.A.

MANUAL INSTRUCTIONS FOR GLOBE VALVES

POLÍGONO INDUSTRIAL KALZADAKO (SARATXO)

01468 AMURRIO – ÁLAVA

☎- +34 945 891 561 FAX: +34 945 892 227

E-MAIL: INFO@LAZAROITUARTE.COM



Instructions Manual - Globe Valve

Copyright Lázaro Ituarte Internacional, S.A., 2002. All rights reserved.

This document must be used only for the purpose for which it is published.

This document, as well as the information contained in it, is property of Lázaro Ituarte Internacional, S.A., and must not be reproduced totally or partially by any information or communications means without the express approval of Lázaro Ituarte Internacional, S.A.



TABLE OF CONTENTS

		Page
1	GLOBE VALVE DRAWINGS 1.1.- Globe valve bolted-bonnet and pressure-seal 1.2.- Optional accessories	3 4
2	INTRODUCTION 2.1.- General Notes 2.2.- Description in details of optional accessories	5 6
3	SERVICE REQUERIMENT AND USER INDICATIONS 2.1.- Service requirements 2.2.- User indications	7 7
4	HANDLING AND STORAGE 4.1.- Handling 4.2.- Storage before installation	9 10
5	INSTALLATION 5.1.- Checking before installation 5.2.- Ends connections 5.3.- Butt welding connections 5.4.- Considerations after installation	11 12 12 12
6	MAINTENANCE	13
7	RECOMMENDED SPARE PARTS	14



1.1 GLOBE VALVE

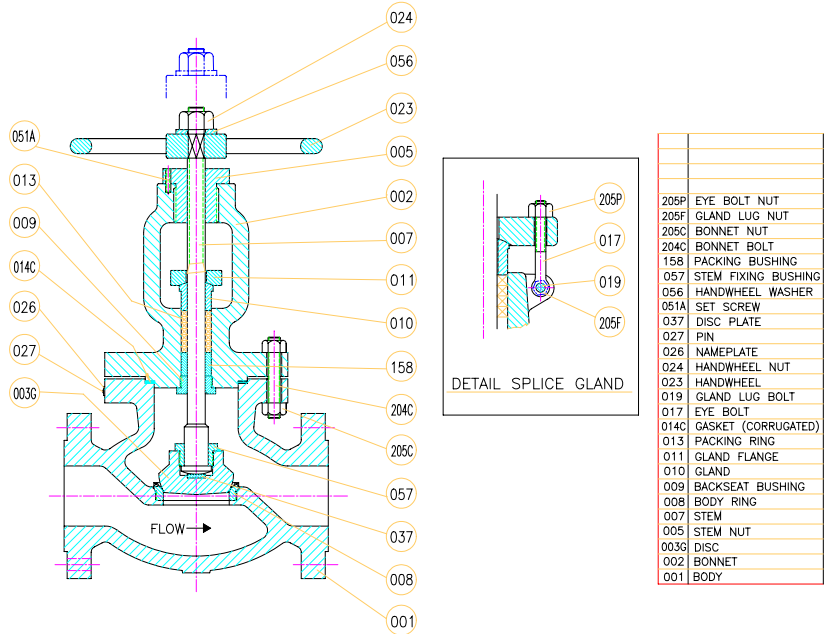

FIG. 1A

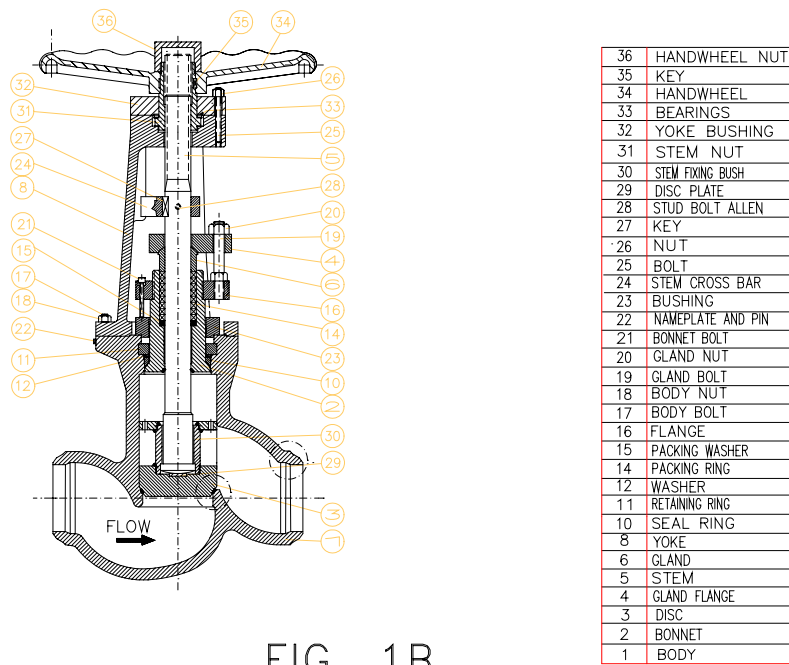

FIG. 1B



1.2 OPTIONAL ACCESSORIES

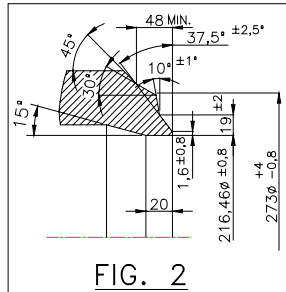

FIG. 2

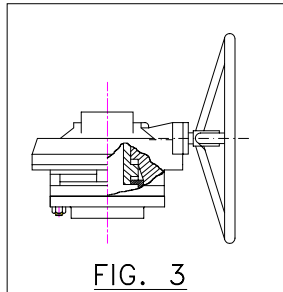

FIG. 3

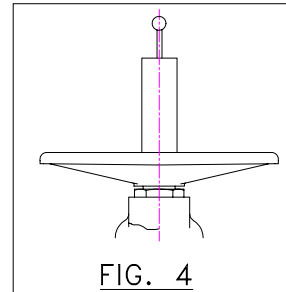

FIG. 4

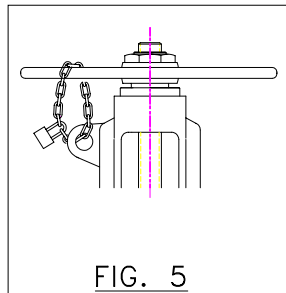

FIG. 5

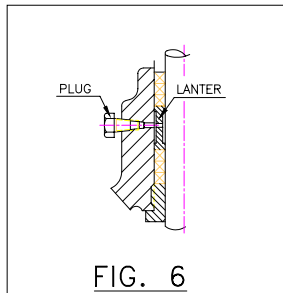

FIG. 6

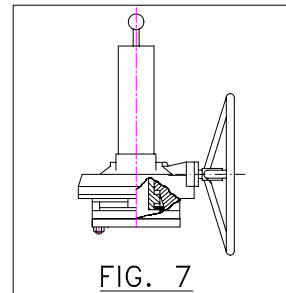

FIG. 7

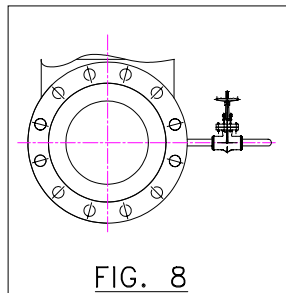

FIG. 8

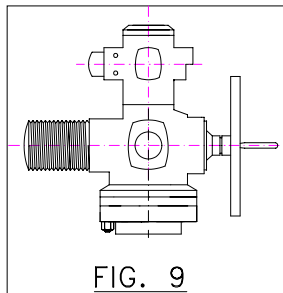

FIG. 9

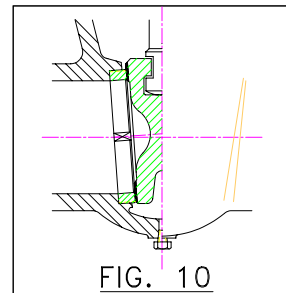

FIG. 10

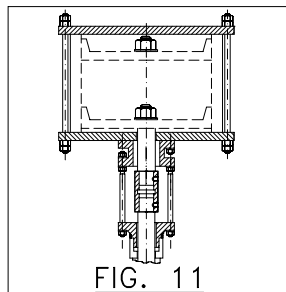

FIG. 11

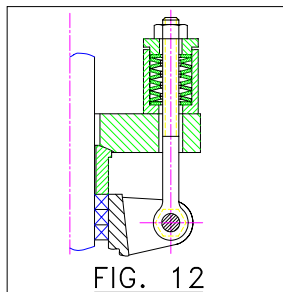

FIG. 12

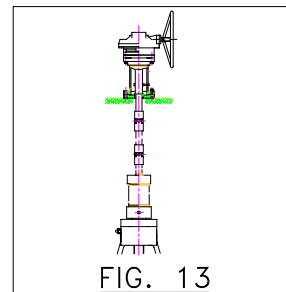

FIG. 13

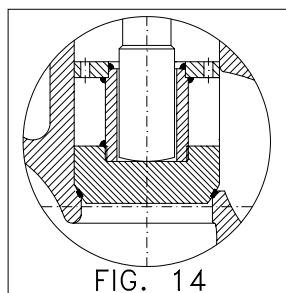

FIG. 14



2.- INTRODUCTION

2.1.- GENERAL NOTES

This Instructions Manual has been prepared by the Engineering Department of *Lázaro Ituarte Internacional, S.A* in order to give to the user the storage, maintenance, handling and installation instructions for the supplied valves .

In case the user may require any scope of manipulation in the valve, it is required to contact firstly and beforehand the manufacturer in order to avoid defects resulting from wrong manipulation of the valve.

WARNING

This instructions manual describes the most suitable procedures for a correct handling, installation and maintenance for the valves manufactured by Lazaro Ituarte. These procedures must be followed step by step and thoughtfully to prevent damage caused by any misuse or manipulation.

The valves as all the equipment subject to pressure can be dangerous if not correctly handled.

Do not dismantle any valve device unless prior approval from the manufacturer.



2.2.- DESCRIPTION IN DETAILS OPTIONAL ACCESORIES:

- *Figure 1 A* ► it represents a globe valve, bolted bonnet, including a direct actuation with a wheel and flanged.
- *Figure 1B* ► it represents a pressure-seal globe valve.

Drawings 2 to 14 are options which the user can demand according to his needs:

- *Figure 2* ► it represents butt weld end.
- *Figure 3* ► it represents a bevel gear actuator without stem protection.
- *Figure 4* ► it represents a valve with a direct wheel and position indicator .
- *Figure 5* ► it represents a detail of a standard locking device.
- *Figure 6* ► it represents a packing case with a lantern and plug.
- *Figure 7* ► it represents a valve with a position gauge.
- *Figure 8* ► it represents a by-pass.
- *Figure 9* ► it represents a electric actuator in operation.
- *Figure 10* ► it represents a plug of drain connection its location will be done according to the customer's instructions .
- *Figure 11* ► it represents a hydraulic or pneumatic actuator.
- *Figure 12* ► it represents a detail of live loaded packing.
- *Figure 13* ► it represents an extension stem and platform.
- *Figure 14* ► it represents a globe valve with check closing.



3. - SERVICE REQUIREMENT AND USE

3.1.- SERVICE REQUIREMENT

Globe valves are used primarily for throttling purposes and general flow control in oil, gas, petrochemical, power offshore and other arduous applications. In this cases, when the valve is used for throttling purposes, the pressure drop must not be higher than 20% of the entrance pressure.

They can also be used for on-off service, but because of high pressure drop, this is generally confined to applications where the valve is normally closed and drop is not important when the valve is open.

The globe valve is unidirectional.

3.2.- USER INDICATIONS

- The user will have to select the adequate material to avoid corrosion risks.
- The user will have to select the valve's "class" according to pressure and temperature data in accordance to standards (ASME B16.34 or any applicable standard) in order not to produce efforts above the acceptable limits.
- The user will have to select between standard or special class (according to ASME B 16.34 standard) in order to avoid efforts above the acceptable limits.
- When the valve works at a temperature higher than 454°C or lower than -24°C, the user will have to select the adequate material for the bolting.
- The valve should not be subject to pressures and temperatures higher than those indicated by standards (ASME B16.34 or any applicable standard).
- It should not cause short closing which can cause water hammers.
- When it required, the stem of the valve should be protected with covers to prevent solid particles from settling on it and damaging it.
- In case of balanced water pre-heating, pressure is necessary. The valves will have to function with a by-pass.
- In case of actuator pneumatic, electric or hydraulic actuators with high speed of closing, is recommended coupling of a damper at the end of the course to avoid impacts which can cause damages in the valve.
- In the globe valves it's recommended that the speed of the fluid doesn't be higher than $v = 240\sqrt{v_{esp}}$, with v_{esp} = specific volume of the fluid (pie³/lb).
- It's recommended that the closing of the valve must be higher than 10% the run of the steam, due to the possibility of vibrations, noises and damages in the valve. Even, in that situation, it can appear resonance effects which is dangerous for the operation of the valve.



• ***Globe Valves with check closing (stop-check):***

- The opening of the valve it's realized by the disc.
- The Cv value of the valve is given with the valve completely open.
- The minimum speed of the fluid to open the valve completely can be calculated by :
 $v \geq 40\sqrt{v_{esp}}$, with v_{esp} = specific volume of the fluid (pie³/lb).
- The speed of the fluid must be: $40\sqrt{v_{esp}} \leq v \leq 120\sqrt{v_{esp}}$



4. HANDLING AND STORAGE

Unless otherwise specified and agreed the valve is packed in closed position in standard pallets.

4.1.- HANDLING

The valves with weight lower than 50kg can be handled manually with the wheel, as it is shown on the picture.



For valves with weight 55 kg. and above correct handling is show in picture, the handling is through the yoke. Do not attempt to handle the valve from the hand wheel, the gear box or the actuator.



In order to avoid damage in any part of the valve, we recommend the use of a polyester lifting lug . Using a steel lifting lug, you must especially pay attention that steel in contact with the important parts of the valves, especially the stem. The choice of the lifting lug must be adequate with the weight of the valve.

For stainless steel valves never handle, brush or manipulate with material other than stainless steel. The use of dissolvent halogen ad is not permitted .

For valves with wheel, those should not be actuated with bars, key of nut, or others similar.



4.2.- STORAGE BEFORE INSTALLATION

Valve shall be completely closed and both ends calked with plastic or wood protections attached to the valve's body, these protections must be only withdrawn at the time of the installation.

Steam's surface shall be well lubricated and protected with adhesive tape and packing paper as on the picture.



When the valve is going to be stored during a long time, it's recommendable the packing of the valves in cases protected by waterproof and introduce in the same bags non-humidity.



5. INSTALLATION

A wrong valve installation can bring serious consequences, a bad handling can require expensive services to repair it. When receiving the valve, check the state of the packing in order to note possible external damages which will could have damage the valve.

5.1.- *CHEKING BEFORE INSTALLATION*

- Check on the valve's plate: size, class and trim and make sure that those are adequate for the installation.
- Valve with wheel : open and close fully to test the ease of opening.
- All the precautions necessary must be taken to avoid the introduction of external elements into the valve which can caused serious damage on the seat surface before and after installation.
- The end's protections must be withdrawn in order to clean the close surface by fluxing. At this time the wheel should not be operated.
- It's very important to clean the piping before the installation: small pieces of metal, deposits of welding in the piping can produce a damage on the seat surface of the valve.
- When the valve works with high or low temperature, the valve should not be manipulated before it would be technically equilibrated it could create a loss of seal and in case of galling on stem. and the seats.
- It must be remembered that during the installation the thermal tension piping and the fluid's weight produce considerable mechanics tension to the valve. These, can cause distortions in the body which cause a backlash in the seats and consequently the leaks.
- During the procedure of valve's ends welding to the pipe take attention that metal does not fall on the seat surface. It is also necessary to take into account the high temperature which can deform the seat.

Once checking made of all those different points, the valve is ready to being installed.



5.2.- ENDS CONNECTIONS

- For unidirectional valves, make sure the flow direction according to the valve design.
- The valve's ends will be aligned parallel to the ends of the piping to avoid strong force.
- Once places from there you will process with a partial tightening of all bolting, per pair opposed diametrically around the support.
- You will proceed of the same manner for the total tightening .
- The final tightening will be the corresponding to the size and material of the bolting.

5.3.- BUTT WELDING CONECTIONS

- For unidirectional valves, make sure the flow direction according to the valve design.
- The ends of the valve will be aligned parallel to the ends it piping to avoid efforts.
- To close the valve before proceeding to the welding for protect surface of base.
- When it has been produced changes material structure and thermal stress in the body of the valve during the ends welding process , it will be done a post weld heat treatment.

5.4.- CONSIDERATIONS AFTER INSTALLATION

- Once the valve is installed, the seat surfaces are still vulnerable to foreign particles like sand, deposit of welding in the system of piping. For that it is recommended to carry out cleaning of the system with all the valves open (the back seat must be completely closed) before the plant functions.
- When the valve is installed in high temperature systems, it is advised to verify the closing of nuts and packing screws after a short initial operate period.



6. MAINTENANCE

By programming a periodic maintenance of the valve, potential problems it can be detected and therefore it is possible to extend the life of the valve. The periodic maintenance program must be prepared by the engineering department. The frequency of these revisions must be based on the user's experience who installs the equipment. Lazaro Ituarte International recommends the revision and lubrication of the following parts:

PACKING:

The leaking by the packing box is the most common problem which arrives when the valve is under pressure, regular inspection of this element avoids the leaking through the gland which can damage the stem of the valve. Should leakage be observed through the packing, tightening of the gland nuts is required. Be careful that the gland nuts are not over tightened as this can increase packing friction which can adversely affect the valve performance.

BOLTING:

The systems of piping are subject to certain vibrations which can loosen and disassembled the bolting, therefore, all bolting will have to be checked and inspected regularly.

STEM NUT , PACKING BOLTS:

These parts of the valve should be regularly lubricated to avoid mechanical damage due to the abrasions.

Lubrication fittings situated in the top of the yoke are to facilitate the lubrication.



AUXILIAR EQUIPMENTS:

When the valve is equipped with a bevel gear actuator , electric actuator ... this equipment should have also lubricated regularly according to manufacturer's recommendations.



7. RECOMMENDED SPARE PARTS

The packing ring and the gasket are the recommended spare parts by Lázaro Ituarte Internacional, S.A.

When ordering spares or requesting any information about the globe valve ensure that the following information is quoted:

- type, size and rating globe valve
- valve serial number

Above information is stamped on valve nameplate.